

## GE4 Washboard Inside Release Handle

### Features

- The 'washboard' release represents an evolutionary stage between conventional 'rotary' inside handles and fully-flush designs
- It is a die cast unit with a 'pull-out' handle that affords good grip, while sitting low against the side of the vehicle when in rest position.
- Originally made for luxury cars it also suits trucks and buses and can be supplied with or without safety flaps as illustrated
- Semi-plant-on design for easy installation, 'snap-in' connection and cushioned action
- Lift flap to withdraw latch connection point 'X'
- Safety flap (when fitted) operates separate connecting link to door latch, and blocks main flap
- Handle is fitted to inside door skin. Link rods are attached, and trim panel is applied over ends of handle to conceal bolts

### Material

- Zinc die cast, black powder coated

### Material

- Lock release lever 'Y' has two attachment points, allowing for adjustment of linkages on site

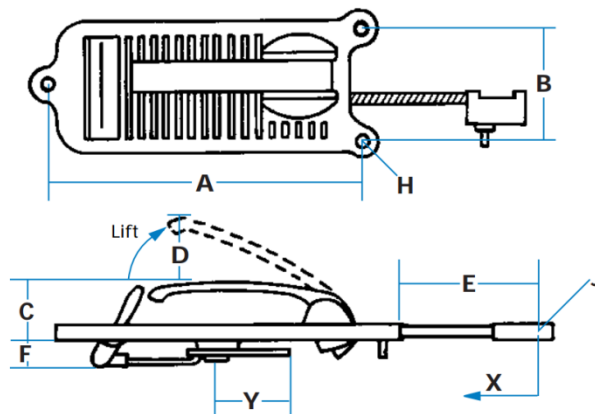

GE4-G01597 (RH)



GE4-G26650B  
(RH, illustrated showing safety flap  
in 'locked' position)

### Installation of 'washboard' release

Illustration shows right-side handle with fully interconnected action through door latch to outside handle. With original scheme a push-button exterior handle was used.

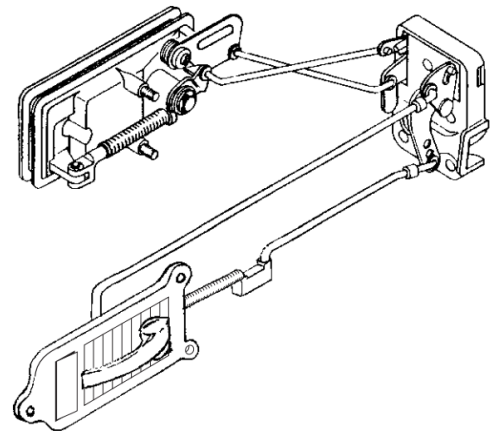

### 'Handing'

Separate base castings, handed by position of connection points and release handle.

Part No.	Safety Flap	Type	A	B	C	D	E	F	H	J	X	Y
GE4-G26650B	Yes	RH	155	53	28	50	75	15	6 mm, c/s 12 mm	3.5	15	22
GE4-G26649B		LH										
GE4-G01597	No	RH										
GE4-G01596		LH										